



XPA **500**
XPA **300**

COMMERCIAL
DIGITAL AMPLIFIER

OWNER'S MANUAL

We at OSD Audio thank you for your purchase of our XPA-500/XPA-300 featuring Energy Efficient Class D Pure 70/100 Volt Commercial Power Amplifiers.

Both these Power Amplifiers are a welcome addition to our 70/100 Volt Lineup. A perfect add on to our current PAM245 or as a stand alone product both Amplifiers deliver 2 Channels of pure 70/100V power. In addition to the great features you've come to expect in an OSD Audio Amplifier, the XPA Amplifiers feature both Unbalanced and Balanced Line Inputs, an included IR-Remote Control, hard-wired IR Receiver module/sensor, an RS232 input for integration with control systems in a compact 1U rack Chassis. The Class D Power Supplies are 93% Efficient.

Don't let their compact size fool you, both amplifiers double down, the XPA-500 is 2 x 500 Watts and the XPA 300 is 2 x 300 Watts

Inside the box:

One 70/100Volt Power Amplifier

One Product Manual

One IR Remote Control/ One IR Receiver Module Sensor Kit

One set of rack mounting hardware including two (2) brackets

AC Power Cord



CAUTION: TO REDUCE THE RISK OF ELECTRIC SHOCK, DO NOT REMOVE COVER (OR BACK) NO USER-SERVICEABLE PARTS INSIDE REFER SERVICE TO QUALIFIED SERVICE PERSONNEL



The lightning flash with arrowhead symbol within an equilateral triangle is intended to alert the user to the presence of un-insulated "dangerous voltage" within the product's enclosure that may be of sufficient magnitude to constitute a risk of electric shock.



The exclamation point within an equilateral triangle is intended to alert the user to the presence of important operating and maintenance (servicing) instructions in the literature accompanying the appliance.

WARNING TO REDUCE THE RISK OF FIRE OR ELECTRICSHOCK,DO NOT EXPOSE THIS APPLIANCE TO RAIN OR MOISTURE.

This product was designed and manufactured to meet strict quality and safety standards. There are, however, some installation and operation precautions, which you should be particularly aware of.

1. **Read Instructions** - All the safety and operating instructions should be read before the appliance is operated.
2. **Retain Instructions** - The safety and operating instructions should be retained for future reference.
3. **Heed Warnings** - All warnings on appliance and in the operating instructions should be adhered to.
4. **Follow instructions** - All operating and use instructions should be followed.
5. **Water and Moisture** - The appliance should not be used near water - for example, near a bathtub, washbowl, kitchen sink, laundry tub, in a wet basement, or near a swimming pool, etc.
6. **Carts and Stands** - The appliance should be only with a cart or stand that is recommended by the manufacturer. An appliance and cart combination should be moved with care. Quick stops, excessive force, and uneven surfaces may cause the appliance and cart combination to overturn.



7. **Wall or Ceiling Mounting** – The appliance should be mounted to wall or ceiling only as recommended by the manufacturer.
8. **Ventilation** – The appliance should be situated so that its location or position does not interfere with its proper ventilation. For example, the appliance should not be situated on a bed, sofa, rug or similar surface that may block the ventilation openings; or, place in a built-in installation, such as a bookcase or cabinet that may impede the flow of air through the ventilation openings.
9. **Heat** – Do not install near any heat sources such as radiators, heat registers, stoves, or other apparatus (including amplifiers) that produce heat.
10. **Power Sources** – The appliance should be connected to a power supply only of the type described in the operation instructions or as marked on the appliance.
11. **Grounding or Polarization** – Do not defeat the safety purpose of the polarized or grounding-type plug. A polarized plug has two blades with one wider than the other. A grounding type plug has two blades and a third grounding prong. The wide blade or the third grounding prong are provide for your safety. If the provided plug does not fit into your outlet, consult an electrician for replacement of the obsolete outlet.
12. **Power-Cord Protection** – Power supply cords should be routed so that they are not likely to be walked on or pinched by items placed upon or against them, paying particular attention to cord at plugs, convenience receptacles, and the point where they exit from the appliance.
13. **Cleaning** – Clean only with dry cloth.
14. **Power Lines** – An outdoor antenna should be located away from the power lines.
15. **Nonuse Periods** – The power cord of the appliance should be unplugged from the outlet when left unused for a long period of time.
16. **Accessories** – Only use attachments/accessories specified by the manufacturer.
17. **Object and Liquid Entry** – Care should be taken so that objects do not fall and liquids are not spilled into the enclosure through openings.
18. **Damage Requiring Service** – The appliance should be serviced by qualified service Personnel when:
 - A. The Power-supply cord or the plug has been damaged; or
 - B. Objects have fallen, or liquid has spilled into the appliance; or
 - C. The appliance has been exposed to rain; or
 - D. The appliance does not appear to operate normally or exhibits a marked change in performance; or
 - E. The appliance has been dropped, or the enclosure damaged.
19. **Servicing** – The user should not attempt to service the appliance beyond that described in the operating instructions. All other servicing should be referred to qualified service personnel.

FEATURES	XPA500	XPA300
Power Output	500 Watts Per Channel	300 Watts Per Channel
Design	Class D 93% Efficient	
Inputs	Balance and Unbalanced Inputs	
Outputs	Unbalanced Loop Line Output to Another Amplifier	
12V Trigger	For Remote Turn On	
12V Trigger	Out to Trigger External Device	
70V/100V	Selectable Rear Panel Swit	
IR Remote	IR Remote Included/ Hard Wired IR Receiver/ Codes Availab	
RS232	RS232 Querries & Commands Available	
Output Level Meter	Front Panel Status; Protection & Warning LEDs	
Chassis Design	1U Rack	
Voltage	Multi-Voltage: AC115/230V	

SPECIFICATIONS	XPA500	XPA300
Power Output	500W X2	300 W X2
THD	1% (Rated Power)	
Signal To Noise	>90dB A Weighted	
Freq Response	20Hz - 22kHz +/-2dB	
Adjustable Level	Min - Max	
Line Level Input Sensitivity	510mV	
Thermal Protection	Yes	
Short Protection	Yes	
Dimensions (WxHxD)	435mm x 44mm x 240mm 17" x 1.7" x 9.4"	
Weight	4.2Kgs / 9.25lbs	

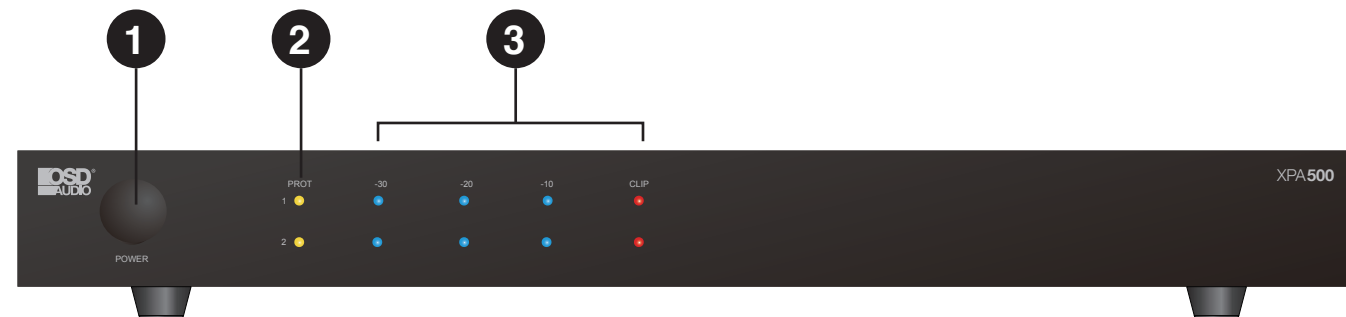

1. Power Switch
2. Protection LED: Normal (Blue) Protection (Red)
3. Output Level Meter: 3 LEDs for each channel -30, -20, -10 (Flashing Blue) Clip Indicator (Red Light) Illuminates when each channel clips.

NOTE: If clipping occurs turn the gain control down on the back of the amp.

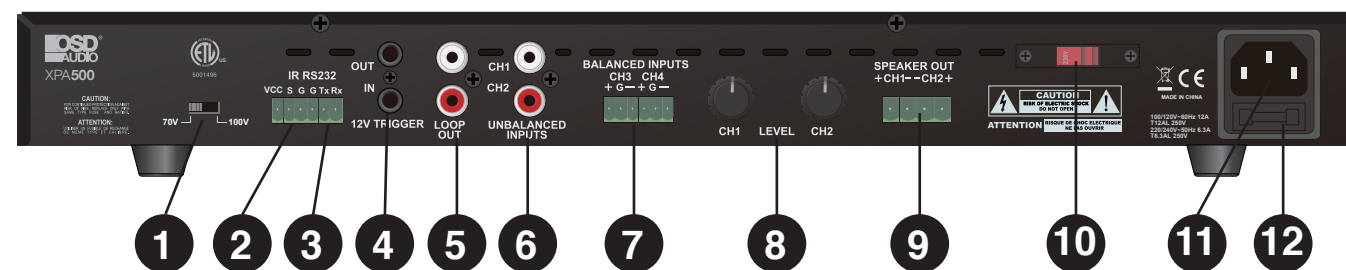

1. 70/100V Selector: 70V for U.S., 100V for Europe
2. RS232 Control
3. IR Receiver Connection
4. 12V Trigger In & Out: Apply 4.5-15 Volts DC to turn Amplifier On, Link other equipment connected to the 12V Out with the same 12V signal.
5. Audio Loop Outputs: RCA Connections, unbalanced mono for sending audio from channel one (1) to channel two (2) or output to other components.
6. Unbalanced Inputs: Unbalanced mono RCA Source inputs for Channels One (1) and Two (2)
7. Balanced Inputs Connector 3 & 4: Six Pin Set Screw connector for two Balanced Input Connections for Channels 3 and 4
8. Output Gain Controls: Ch1 & Ch2 Level control knob for Channels 1 and 2. Turn clockwise to increase and counterclockwise to decrease output levels.
9. Speaker Output Connector: Speaker output connector with set screw for Channels one (1) and two (2)
10. Multi Voltage Selector Switch: 115V or 230V
11. IEC Power Receptacle
12. AC Fuse/Holder

The following information is provided for reference only. Please consult a professional if unsure about any aspects of commercial or residential installations.

Speaker Connection

The rear panel of the amplifier contains 2 Line Outputs (Line 1 and Line 2). **BE SURE TO CONNECT SPEAKERS PROPERLY**, see line voltage instructions below. The speaker lines are to be connected directly between the appropriate COM terminal on the terminal strip and the terminal corresponding to the impedance of the speaker(s). Connect the cables to the terminals on the screw terminal strip provided. Use the screw terminals which correspond to the proper polarity of the speaker(s). One lead must always be connected to the COM.

IMPORTANT NOTICE: When 70V constant line voltages are used, a line matching transformer must be used with each speaker. All transformers must be connected in parallel.

ALWAYS CONNECT LINE TRANSFORMERS IN PARALLEL, NEVER CONNECT IN SERIES

Speaker Impedances

Speaker terminal taps for 70V constant line voltage are provided on the rear panel of the unit. To connect the power output directly to a speaker or PA horn or a combination of speakers and/or PA horns, connect to the COM and (+) terminal on the strip. Be sure the speaker(s) or PA horn(s) can handle a reasonable power output from the amplifier or permanent damage to the speaker(s) or PA horn(s) may result. Also, be careful not to overload the amplifier with too many speakers or PA horns. If it is desired to use a number and variety of speakers, the speakers must be arranged in various series or parallel arrays to provide proper impedance matching. 70V constant line voltage must be used (parallel connection only). If you are not familiar with impedance matching, consult a professional installer or technician for advice. If 70V constant line voltages are used, a line matching transformer must be used with each speaker. Again do not overload or use incompatible speakers. Line transformers are the preferred method for multi-speaker installation.

Cable Requirements

Output cabling need not be shield in most case and should be of sufficient gauge to minimize losses due to the resistance of the wire over long runs (insertion loss). Cable thinner than 18 gauge AWG is not recommended. Long runs require 16 gauge AWG or heavier.

In some cases where the output cable is run in close proximity to unshielded intercom cables, electrical cables, radio transmission antennas or other sources of interference, or when the amplifier is being used for paging from a telephone system, the amplifier may require shielded output cabling to prevent audio feedback or interference.

WHENEVER IN DOUBT ABOUT INSTALLATION, CONSULT WITH A PROFESSIONAL INSTALLER OR TECHNICIAN. OTHERWISE, PERSONAL INJURY, DAMAGE TO THIS AMPLIFIER AND/OR SPEAKERS MAY RESULT AND YOUR WARRANTY MAY BE VOID.

Rack Mounting

The XPA-300/500 both come with Rack Mounts in the box. Remove the two chassis screws from each side panel, closest to the front panel. Attach the rack-mount ears to the sides of the front face plate using the screws that come with the rack mounts (2 each side).

The amplifier will occupy 1U of rack space. Ensure that the unit is in a well-ventilated area that provides adequate cooling. Free air space is required above the amplifier and below the amplifier. The recommended distance is 1U to 2U, 1.75" to 3.5" being sure to avoid blocking any vents on the unit's chassis.

Bottom feet on the amplifier chassis may be removed if necessary. **NOTE:** Do not place the screws back into the chassis. Without the feet, the length of the screw may touch internal components and affect the performance of the amplifier.

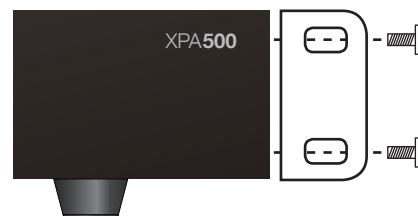

Balanced Input

Use the BALANCED INPUT to connect balanced or unbalanced cables to the amplifier.

NOTE: The unbalanced connection needs a jumper from the Shield to the Negative. The unbalanced connection is used when there is no balanced source and more additional connections to the amp are needed.

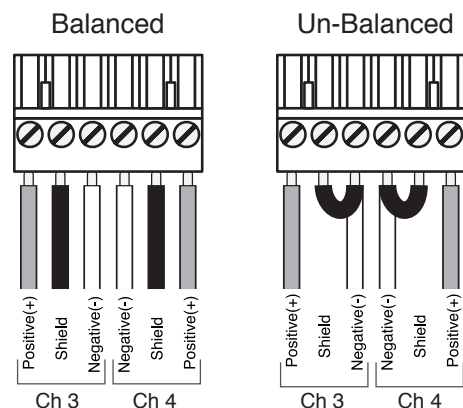

Unbalanced Connections

Use standard RCA cables to connect sources using the UNBALANCED LINE IN input. Connect sources through the applicable mono input. Use the LOOP OUT ports to connect more amplifiers or equipment.

Unbalanced Loop Out 1 & 2 Unbalanced Line In 1 & 2

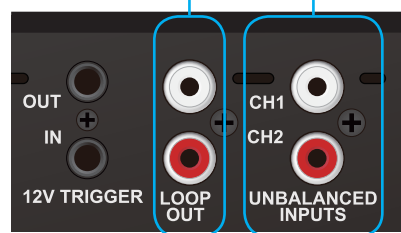

Using Fixed Loop Out

The LOOP OUT connections on the amplifier may be used to send audio signals to other equipment, or to the other channel of the amplifier. This connection sends audio signals out from the UNBALANCED INPUT of the channel.

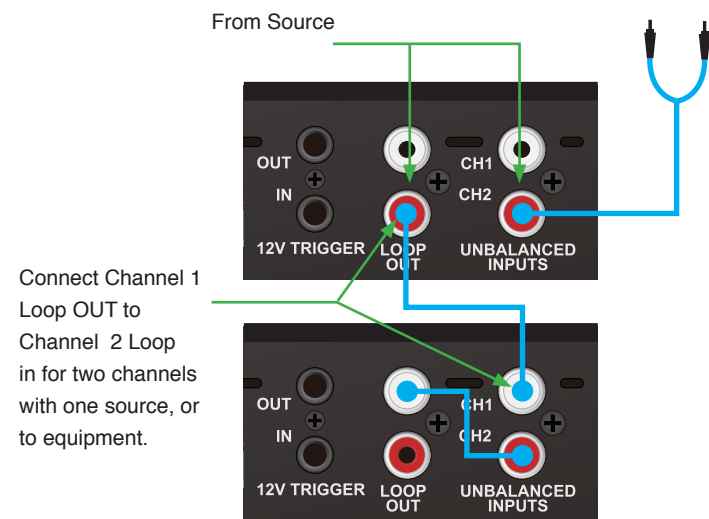

Connect Channel 1 Loop OUT to Channel 2 Loop in for two channels with one source, or to equipment.

Single Source W/ Stereo Output

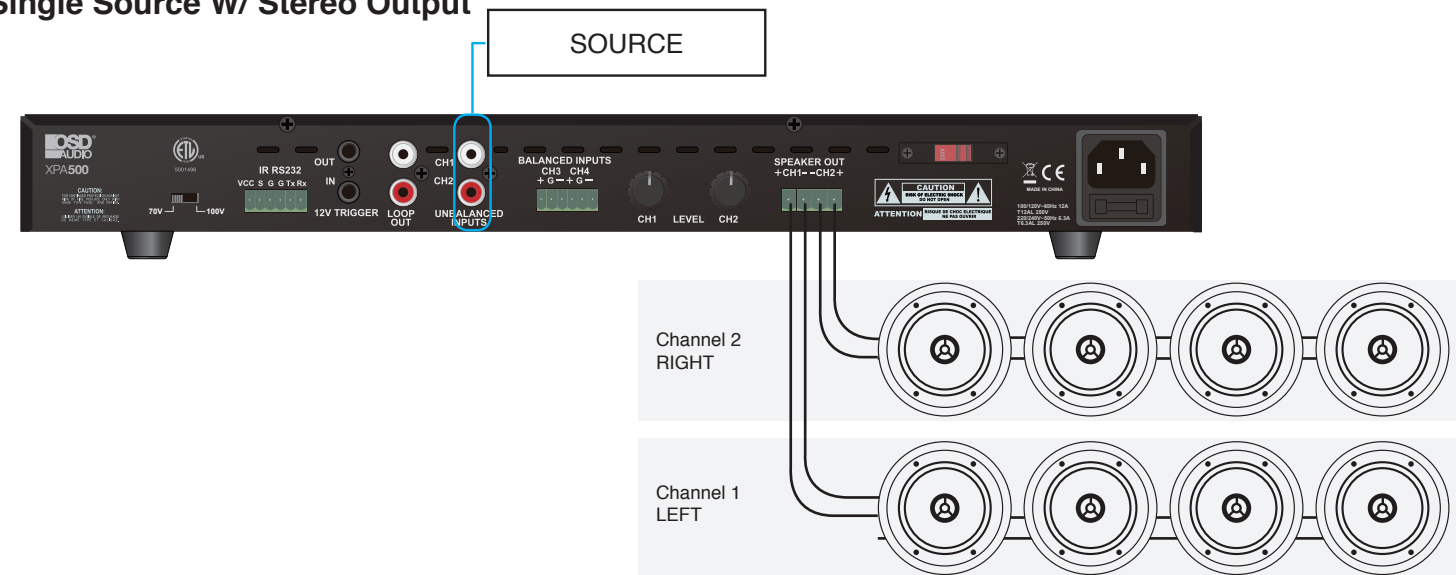

Two Source W/ Two Mono Output Zones

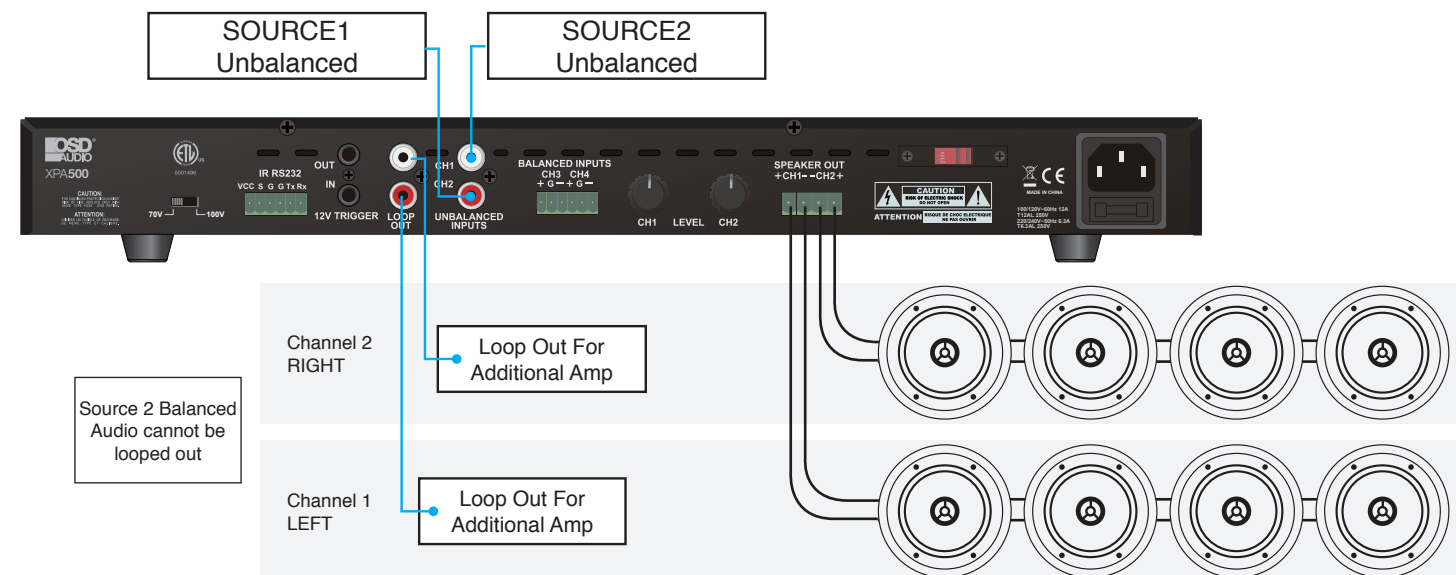

Single Mono Source Unbalanced

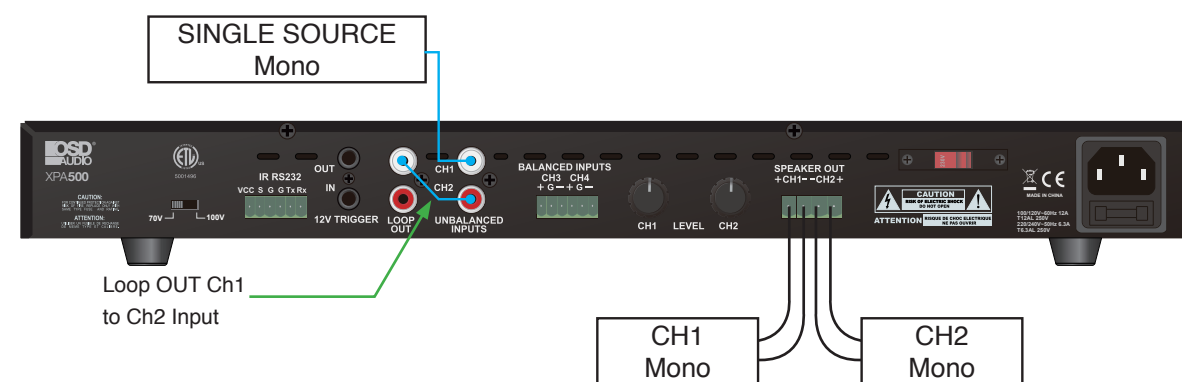

XPA IR Remote

The XPA-300 and XPA-500 IR Remote Controller, controls the individual zones on our PAM-1270 amplifier. It can also be used to teach IR commands to a programmable, integrated universal IR Remote, zone control system or other IR routing device

Both of the XPA-300 and the XPA-500 come with a IR Receiver module that connects to the IR two conductor input connector. There is no built in IR Sensor. The following are brief descriptions of each button. Universal IR codes are also available on the next page of the Owners Manual.

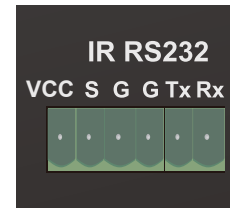

IR Remote Function

1. IR LED - One, high-output IR LED. The IR LED flashes invisible (infrared light pulses that are the control codes for the XPA-300 & XPA-500. The LED must be pointed at an IR receiver that is connected to an XPA-300/500. The IR Receiver Sensor must be connected to the IR 2 Conductor Connector
2. Power On/Off- Separate Power On (Red Button) and Power Off.
3. Source Selects between the Unbalanced and Balanced Sources
4. Ch1 Vol+, Vol- & Mute – CH1-Unbalanced/CH3-Balanced; Volume Up. CH1-Unbalanced/CH3-Balanced and Mute for CH1 and CH3
5. Ch2 Vol+, Vol- & Mute – CH2-Unbalanced/CH4-Balanced; Volume Up. CH2-Unbalanced/CH4-Balanced and Mute for CH2 and CH4
6. All Channels Vol+, Vol- & Mute – All Channels-Unbalanced/ Balanced; Volume Up. All Channels-Unbalanced/Balanced and Mute for All Channels

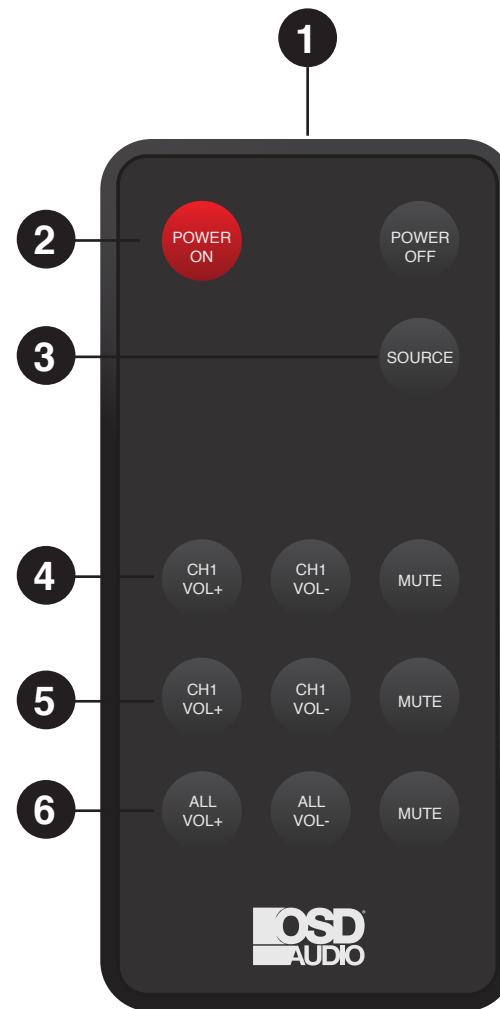

XPA IR Remote Universal Codes

The XPA 70V Amplifiers IR Remote Controller, controls the individual Power On/Off, Source, and the Volume Levels for Channels 1/3 & 2/4 and All Channels combined. It can also be used to teach IR commands to a programmable, integrated universal IR Remote or other IR routing device. The following are the Remote Controller Head Code and Hex codes for the individual buttons:

XPA300/XPA500 Remote Controller Head Code: 00FF

Function Key	Keys	Code	Remark
Power On	K1	45	power turn amplifier on
Power Off	K2	47	power turn amplifier off
Source	K3	43	RCA Balance/UnBalanced Inpus select
CH1 VOL +	K4	16	CH1/CH3 VOL UP
CH1 VOL -	K5	19	CH1/CH3 VOL DOWN
MUTE	K6	0D	CH1/CH3 Silence audio on amp
CH2 Vol +	K7	0C	CH2/CH34 VOL UP
CH2 Vol -	K8	18	CH2/CH34 VOL DOWN
MUTE	K9	5E	CH2/CH4 Silence audio on amp
All VOL +	K10	08	CH1+CH2 and CH3/CH4 VOL UP
All VOL -	K11	1C	CH1+CH2 and CH3/CH4 VOL DOWN
MUTE	K12	5A	CH1+CH2 and CH3+CH4 Silence audio on amp

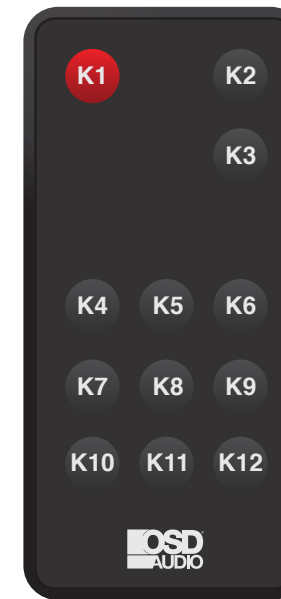

XPA300/XPA500 RS232 Commands

Sequence #	Name	Command	Remark
1	<CR>:	Enter Key	
2	<Esc>:	Escape Key	
3	<Spaec>:	Space Key	
4	Nov<CR>		Show All PA Status:
5	Power<Space>On<CR>	Power On	Power On/Off Control:
6	Power<Space>Off<CR>	Power Off	Power On/Off Control:
7	Power<Space>Toggle<CR>	Power Toggle Control	Power On/Off Control
8	Source<Space>1<CR>	RCA (Unbalanced Inputs)	Source Control:
9	Source<Space>2<CR>	Balanced Inputs	Source Control:
10	Volume<Space>xx<CR>	Volume xx (xx range 00-63)	Total Volume Control: 00 to MIN; 63 to MAX
11	Volume<Space>01<CR>	Setting Volume as 01 level	Total Volume Control
12	Mute<Space> On<CR>	Mute On RCA (Unbalanced/balanced inputs)	Mute Control
13	Mute<Space>Off<CR>	Mute Off RCA (Unbalanced/balanced inputs)	Mute Control
14	Mute<Space>Toggle<CR>	Mute Toggle Control	Mute On/Off Control
15	Ch1 Mute On/Off/Toggle	Ch1 Mute On/Ch1 Mute Off/Ch1 Toggle	Ch1/Ch3 Mute Control
16	Ch2 Mute On/Off/Toggle	Ch2 Mute On/Ch2 Mute Off/Ch2 Toggle	Ch2/Ch4 Mute Control
17	Attenuator xx(00-31)	Ch1 Ch2 Vol	Total Attenuator
18	Ch1 Attenuator xx(00-31)	Ch1 Vol(xx range 00-31)	Ch1 Volume Attenuator
19	Ch2 Attenuator xx(00-31)	Ch2 Vol(xx range 00-31)	Ch2 Volume Attenuator
20	Save<CR>	Store all current setting w/out power on/off status	

WARRANTY

OSD Audio electronics have (2) year Limited Warranty against defects in materials and workmanship. Proof of purchase must accompany all claims. During the warranty period OSD Audio will replace any defective part and correct any defect in workmanship without charge for either parts or labor.

OSD Audio may replace returned electronics with a product of equal value and performance. In such cases, some modifications to the mounting may be necessary and are not OSD Audio's responsibility.

For this warranty to apply, the unit must be installed and used according to its written instructions. If necessary, repairs must be performed by OSD Audio. The unit must be returned to OSD Audio at the owner's expense and with prior written permission. Accidental damage and shipping damage are not considered defects, nor is damaged resulting from abuse or from servicing performed by an agency or person not specifically authorized in writing by OSD Audio.

OSD Audio sells products only through authorized dealers and distributors to ensure that customers obtain proper support and service. Any OSD Audio product purchased from an unauthorized dealer or other source, including retailers, mail order dealers and online sellers will not be honored or serviced under existing OSD Audio warranty policy. Any sale of product by an unauthorized source or other manner not authorized by OSD Audio shall void the warranty on the applicable product.

Damage to or destruction of components due to application of excessive power voids the warranty on those parts. In these cases, repairs will be made on the basis of the retail value of the parts and labor. To return for repairs, you must email customer service at RMA@audiogeargroup.com for a Returned Merchandise Authorization (RMA) number then the unit must be shipped to OSD Audio at the owner's expense, along with a note explaining the nature of service required. Be sure to pack the product(s) in a corrugated container with at least 3 inches of resilient material to protect the unit from damage in transit.

This Warranty Does Not Cover: Damage caused by abuse, accident, misuse, negligence, or improper operation (installation) • Any products that have been altered or modified • Any product whose identifying number of decal, serial #, etc. has been altered, defaced or removed • Normal wear and maintenance.



OSD Audio | Brea, CA. | osdaudio.com