



XPA**1000**  
XPA**600**

COMMERCIAL  
DIGITAL AMPLIFIER

# OWNER'S **MANUAL**

# INTRODUCTION

We at OSD Audio thank you for your purchase of our XPA-1000/XPA-600 featuring Energy Efficient Class D Pure 70/100 Volt Commercial Power Amplifiers.

Both these Power Amplifiers are a welcome addition to our 70/100 Volt Lineup. A perfect add on to our current PAM245 or as a stand alone product both Amplifiers deliver 2 Channels of pure 70/100V power. In addition to the great features you've come to expect in an OSD Audio Amplifier, the XPA Amplifiers feature both Unbalanced and Balanced Line Inputs, an included IR-Remote Control, hard-wired IR Receiver module/sensor, an RS232 input for integration with control systems in a compact 1U rack Chassis. The Class D Power Supplies are 93% Efficient.

Don't let their compact size fool you, both amplifiers double down, the XPA-1000 is 2 x 500 Watts and the XPA 600 is 2 x 300 Watts

Inside the box:

One 70/100Volt Power Amplifier

One Product Manual

One IR Remote Control/ One IR Receiver Module Sensor Kit

One set of rack mounting hardware including two (2) brackets

AC Power Cord

# SAFETY



**CAUTION: TO REDUCE THE RISK OF ELECTRIC SHOCK,  
DO NOT REMOVE COVER ( OR BACK )  
NO USER-SERVICEABLE PARTS INSIDE  
REFER SERVICE TO QUALIFIED SERVICE PERSONNEL**



The lightning flash with arrowhead symbol within an equilateral triangle is intended to alert the user to the presence of un-insulated “dangerous voltage” within the product’s enclosure that may be of sufficient magnitude to constitute a risk of electric shock.



The exclamation point within an equilateral triangle is intended to alert the user to the presence of important operating and maintenance (servicing) instructions in the literature accompanying the appliance.

**WARNING TO REDUCE THE RISK OF FIRE OR ELECTRICSHOCK,DO NOT EXPOSE THIS APPLIANCE TO RAIN OR MOISTURE.**

This product was designed and manufactured to meet strict quality and safety standards. There are, however, some installation and operation precautions, which you should be particularly aware of.

1. **Read Instructions** - All the safety and operating instructions should be read before the appliance is operated.
2. **Retain Instructions** - The safety and operating instructions should be retained for future reference.
3. **Heed Warnings** - All warnings on appliance and in the operating instructions should be adhered to.
4. **Follow instructions** - All operating and use instructions should be followed.
5. **Water and Moisture** - The appliance should not be used near water - for example, near a bathtub, washbowl, kitchen sink, laundry tub, in a wet basement, or near a swimming pool, etc.
6. **Carts and Stands** - The appliance should be only with a cart or stand that is recommended by the manufacturer. An appliance and cart combination should be moved with care. Quick stops, excessive force, and uneven surfaces may cause the appliance and cart combination to overturn.



53125A

## SAFETY

7. **Wall or Ceiling Mounting** – The appliance should be mounted to wall or ceiling only as recommended by the manufacturer.
8. **Ventilation** – The appliance should be situated so that its location or position does not interfere with its proper ventilation. For example, the appliance should not be situated on a bed, sofa, rug or similar surface that may block the ventilation openings; or, place in a built-in installation, such as a bookcase or cabinet that may impede the flow of air through the ventilation openings.
9. **Heat** – Do not install near any heat sources such as radiators, heat registers, stoves, or other apparatus ( including amplifiers ) that produce heat.
10. **Power Sources** – The appliance should be connected to a power supply only of the type described in the operation instructions or as marked on the appliance.
11. **Grounding or Polarization** – Do not defeat the safety purpose of the polarized or grounding-type plug. A polarized plug has two blades with one wider than the other. A grounding type plug has two blades and a third grounding prong. The wide blade or the third grounding prong are provide for your safety. If the provided plug does not fit into your outlet, consult an electrician for replacement of the obsolete outlet.
12. **Power-Cord Protection** – Power supply cords should be routed so that they are not likely to be walked on or pinched by items placed upon or against them, paying particular attention to cord at plugs, convenience receptacles, and the point where they exit from the appliance.
13. **Cleaning** – Clean only with dry cloth.
14. **Power Lines** – An outdoor antenna should be located away from the power lines.
15. **Nonuse Periods** – The power cord of the appliance should be unplugged from the outlet when left unused for a long period of time.
16. **Accessories** – Only use attachments/accessories specified by the manufacturer.
17. **Object and Liquid Entry** – Care should be taken so that objects do not fall and liquids are not spilled into the enclosure through openings.
18. **Damage Requiring Service** – The appliance should be serviced by qualified service Personnel when:
  - A. The Power-supply cord or the plug has been damaged; or
  - B. Objects have fallen, or liquid has spilled into the appliance; or
  - C. The appliance has been exposed to rain; or
  - D. The appliance does not appear to operate normally or exhibits a marked change in performance; or
  - E. The appliance has been dropped, or the enclosure damaged.
19. **Servicing** – The user should not attempt to service the appliance beyond that described in the operating instructions. All other servicing should be referred to qualified service personnel.

# FEATURES & SPECIFICATIONS

FEATURES	XPA1000	XPA600
Power Output	500 Watts Per Channel	300 Watts Per Channel
Design	Class D 93% Efficient	
Inputs	Balance and Unbalanced Inputs	
Outputs	Unbalanced Loop Line Output to Another Amplifier	
12V Trigger	For Remote Turn On	
12V Trigger	Out to Trigger External Device	
70V/100V	Selectable Rear Panel Swit	
IR Remote	IR Remote Included/ Hard Wired IR Receiver/ Codes Availab	
RS232	RS232 Querries & Commands Available	
Output Level Meter	Front Panel Status; Protection & Warning LEDs	
Chassis Design	1U Rack	
Voltage	Multi-Voltage: AC115/230V	

SPECIFICATIONS	XPA1000	XPA600
Power Output	500W X2	300 W X2
THD	1% (Rated Power)	
Signal To Noise	>90dB A Weighted	
Freq Response	20Hz - 22kHz +/-2dB	
Adjustable Level	Min - Max	
Line Level Input Sensitivity	510mV	
Thermal Protection	Yes	
Short Protection	Yes	
Dimensions (WxHxD)	435mm x 44mm x 240mm 17" x 1.7" x 9.4"	
Weight	4.2Kgs / 9.25lbs	

## FRONT & REAR PANEL DESCRIPTION

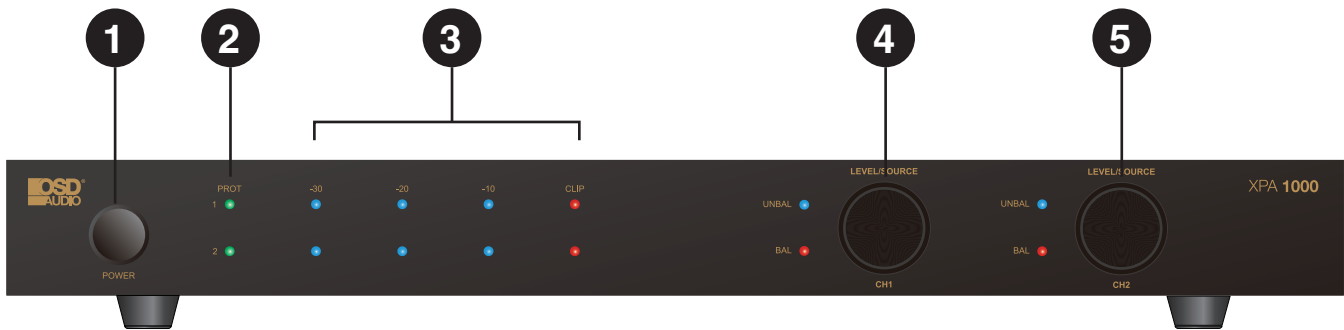

1. Power Switch
2. Protection LED: Normal (Blue) Protection (Red)
3. Output Level Meter: 3 LEDs for each channel -30, -20, -10 (Flashing Blue). Clip Indicator (Red Light) Illuminates when each channel reaches its clipping limit. NOTE: If clipping occurs, adjust the Respective channel level knob (Ch1 or Ch2) to the left to reduce output or to the right to increase signal.
4. Channel 1 Gain Control and Source Select combination knob Turn the knob for Level adjustment and Press the knob to select between Unbalanced and Balanced Source. Status Lite will turn on when selected; Unbalanced: Green, Balanced: Red
5. Channel 2 Gain Control and Source Select combination knob Turn the knob for Level adjustment and Press the knob to select between Unbalanced and Balanced Source. Status Lite will turn on when selected; Unbalanced:

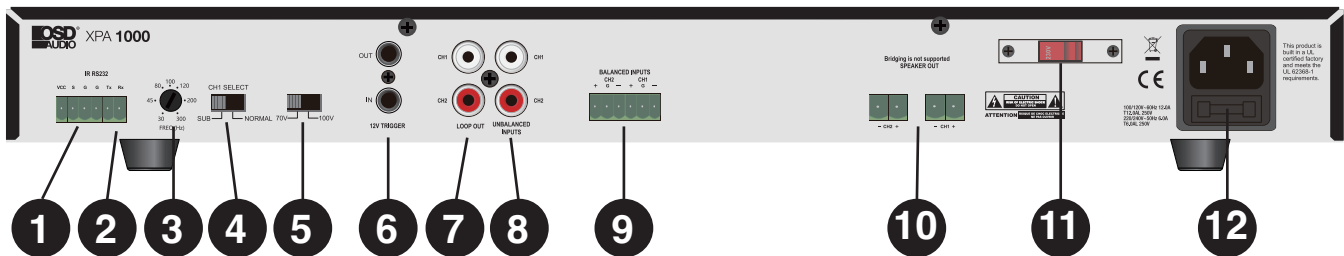

1. IR Remote Control External Receiver connection.
2. RS232 Connection
3. Variable Knob for Low Pass Filter for Channel 1 for dedicated 70Volt Subwoofer (selector switch set to Sub)
4. Selector switch for Channel one, Low Pass Sub, or Normal Full Range.
5. 70/100V Selector: 70V for U.S., 100V for Europe
6. 12V Trigger Input & Output :Apply 4.5 to 15V DC to turn the amplifier on. Link other equipment connected to the 12V Output with the same 12V signal.
7. Audio Loop Outputs: RCA Connections, unbalanced mono for sending audio from channel one to channel two
8. UnbalancedInputs: Unbalanced mono RCA Source inputs for Channels One (1) and Two (2)
9. Balanced Inputs: Channel 1 and Channel 2. Note: Source Selector is on the front panel with Status LED
10. Speaker Output Connector: Speaker output connector with set screw for Channels one (1) and two (2)
11. Multi-Voltage Selector Switch: 115V or 230V
12. AC Power Receptacle and Fuse Holder

The following information is provided for reference only. Please consult a professional if unsure about any aspects of commercial or residential installations.

### **Speaker Connection**

The rear panel of the amplifier contains 2 Line Outputs (Line 1 and Line 2). **BE SURE TO CONNECT SPEAKERS PROPERLY**, see line voltage instructions below. The speaker lines are to be connected directly between the appropriate COM terminal on the terminal strip and the terminal corresponding to the impedance of the speaker(s). Connect the cables to the terminals on the screw terminal strip provided. Use the screw terminals which correspond to the proper polarity of the speaker(s). One lead must always be connected to the COM.

**IMPORTANT NOTICE:** When 70V constant line voltages are used, a line matching transformer must be used with each speaker. All transformers must be connected in parallel.

**ALWAYS CONNECT LINE TRANSFORMERS IN PARALLEL, NEVER CONNECT IN SERIES**

### **Speaker Impedances**

Speaker terminal taps for 70V constant line voltage are provided on the rear panel of the unit. To connect the power output directly to a speaker or PA horn or a combination of speakers and/or PA horns, connect to the COM and (+) terminal on the strip. Be sure the speaker(s) or PA horn(s) can handle a reasonable power output from the amplifier or permanent damage to the speaker(s) or PA horn(s) may result. Also, be careful not to overload the amplifier with too many speakers or PA horns. If it is desired to use a number and variety of speakers, the speakers must be arranged in various series or parallel arrays to provide proper impedance matching. 70V constant line voltage must be used (parallel connection only). If you are not familiar with impedance matching, consult a professional installer or technician for advice. If 70V constant line voltages are used, a line matching transformer must be used with each speaker. Again do not overload or use incompatible speakers. Line transformers are the preferred method for multi-speaker installation.

### **Cable Requirements**

Output cabling need not be shield in most case and should be of sufficient gauge to minimize losses due to the resistance of the wire over long runs (insertion loss). Cable thinner than 18 gauge AWG is not recommended. Long runs require 16 gauge AWG or heavier.

In some cases where the output cable is run in close proximity to unshielded intercom cables, electrical cables, radio transmission antennas or other sources of interference, or when the amplifier is being used for paging from a telephone system, the amplifier may require shielded output cabling to prevent audio feedback or interference.

**WHENEVER IN DOUBT ABOUT INSTALLATION, CONSULT WITH A PROFESSIONAL INSTALLER OR TECHNICIAN. OTHERWISE, PERSONAL INJURY, DAMAGE TO THIS AMPLIFIER AND/OR SPEAKERS MAY RESULT AND YOUR WARRANTY MAY BE VOID.**

## Rack Mounting

The XPA-1000/600 both come with Rack Mounts in the box. Remove the two chassis screws from each side panel, closest to the front panel. Attach the rack-mount ears to the sides of the front face plate using the screws that come with the rack mounts (2 each side). The amplifier will occupy 1U of rack space. Ensure that the unit is in a well-ventilated area that provides adequate cooling. Free air space is required above the amplifier and below the amplifier. The recommended distance is 1U to 2U, 1.75" to 3.5" being sure to avoid blocking any vents on the unit's chassis.

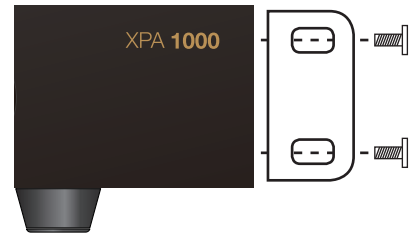

Bottom feet on the amplifier chassis may be removed if necessary.

**NOTE:** Do not place the screws back into the chassis. Without the feet, the length of the screw may touch internal components and affect the performance of the amplifier.

## Balanced Input

Use the BALANCED INPUT to connect balanced or unbalanced cables to the amplifier.

**NOTE:** The unbalanced connection needs a jumper from the Shield to the Negative. The unbalanced connection is used when there is no balanced source and more additional connections to the amp are needed.

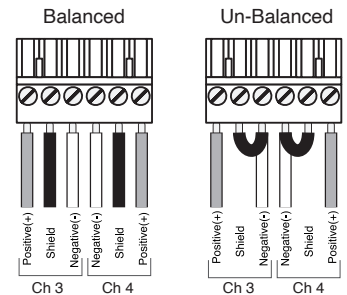

## Unbalanced Connections

Use standard RCA cables to connect sources using the UNBALANCED LINE IN input. Connect sources through the applicable mono input. Use the LOOP OUT ports to connect more amplifiers or equipment.

Unbalanced Loop Out 1 & 2      Unbalanced Line In 1 & 2

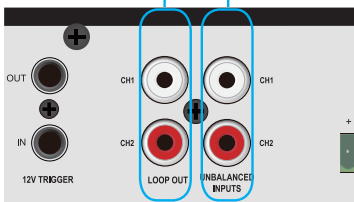

## Using Fixed Loop Out

The LOOP OUT connections on the amplifier may be used to send audio signals to other equipment, or to the other channel of the amplifier. This connection sends audio signals out from the UNBALANCED INPUT of the channel.

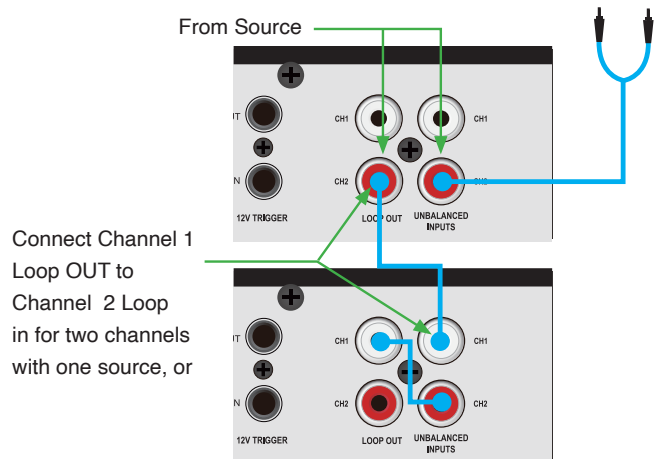

Connect Channel 1 Loop OUT to Channel 2 Loop in for two channels with one source, or

## Connecting a Subwoofer, utilizing the Variable Low Pass Filter

To connect the new Eclipse12 70V outdoor in-ground subwoofer, select the Sub (Low Pass Filter) setting. Then adjust the variable Low Pass Frequency. The Subwoofer is rated at 200W for 70V/100V. The XPA1000 will drive one to two Subwoofers, 200 to 400W of the available 500W on Channel 1. Or drive a single Eclipse 12 70V sub with the XPA600, utilizing 200W of the 300W available watts on Channel 1.

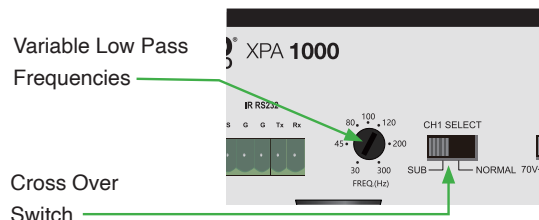

# APPLICATION DIAGRAMS

## Single Source W/ Stereo Output

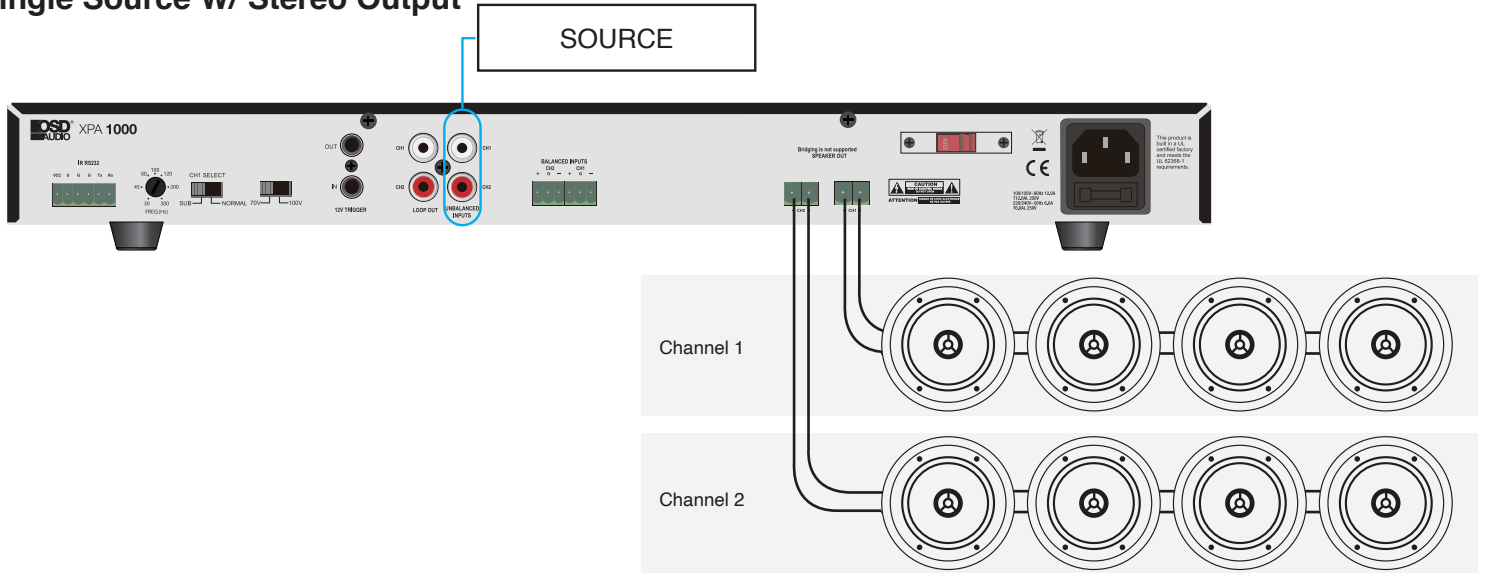

## Two Source W/ Two Mono Output Zones

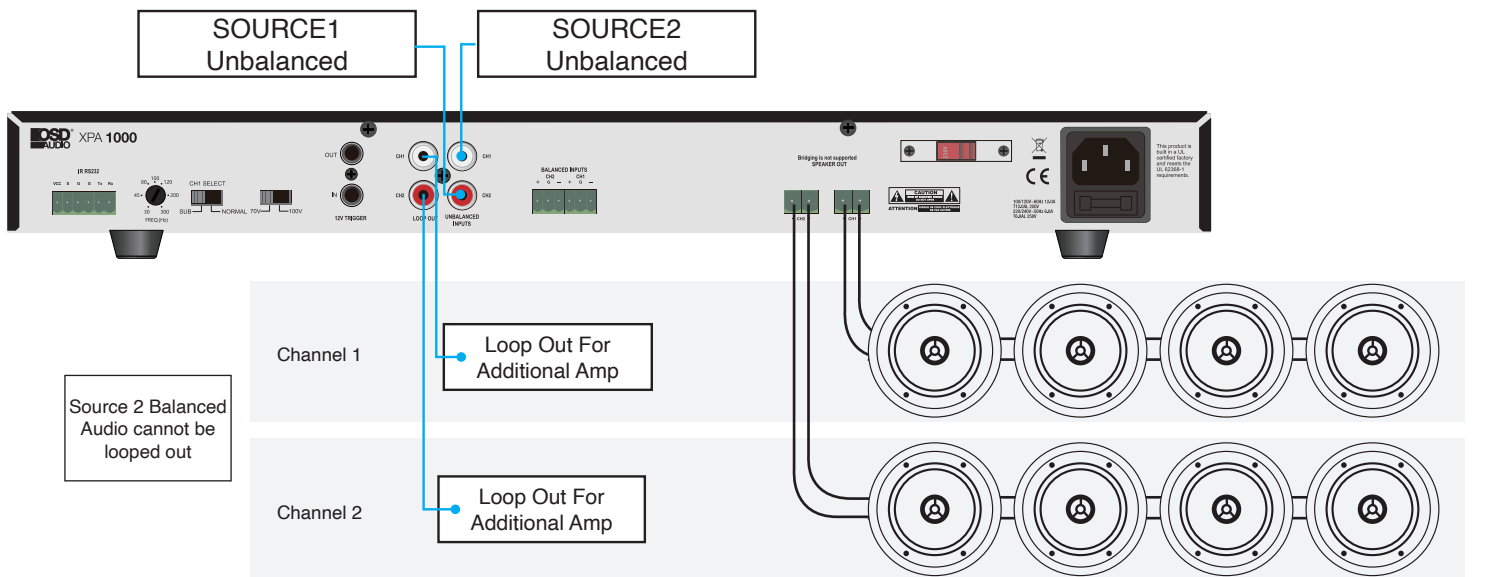

## Single Mono Source Unbalanced

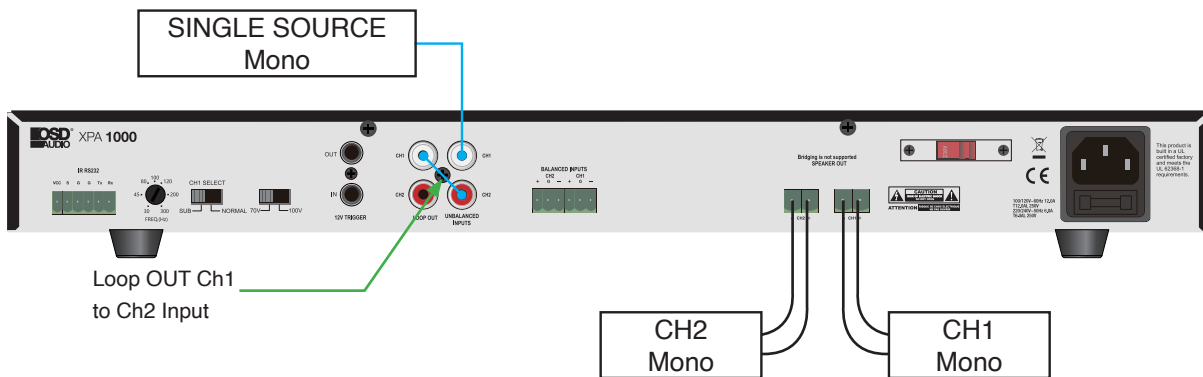

# IR REMOTE CONTROL

## XPA IR Remote

The XPA-1000 and XPA-600 IR Remote Controller, controls the individual zones on our PAM-1270 amplifier. It can also be used to teach IR commands to a programmable, integrated universal IR Remote, zone control system or other IR routing device.

Both of the XPA-1000 and the XPA-600 come with a IR Receiver module that connects to the IR two conductor input connector. There is no built in IR Sensor. The following are brief descriptions of each button. Universal IR codes are also available on the next page of the Owners Manual.

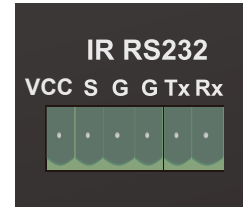

## IR Remote Function

1. IR LED - One, high-output IR LED. The IR LED flashes invisible (infrared light pulses that are the control codes for the XPA-1000 & XPA-600. The LED must be pointed at an IR receiver that is connected to an XPA-1000/600. The IR Receiver Sensor must be connected to the IR 2 Conductor Connector
2. Power On/Off– Separate Power On (Red Button) and Power Off.
3. Source Selects between the Unbalanced and Balanced Sources.
4. Ch1 Vol+, Vol- & Mute – CH1-Unbalanced/CH3-Balanced; Volume Up. CH1-Unbalanced/CH3-Balanced and Mute for CH1 and CH3.
5. Ch2 Vol+, Vol- & Mute – CH2-Unbalanced/CH4-Balanced; Volume Up. CH2-Unbalanced/CH4-Balanced and Mute for CH2 and CH4.
6. All Channels Vol+, Vol- & Mute – All Channels-Unbalanced/Balanced; Volume Up. All Channels-Unbalanced/Balanced and Mute for All Channels.

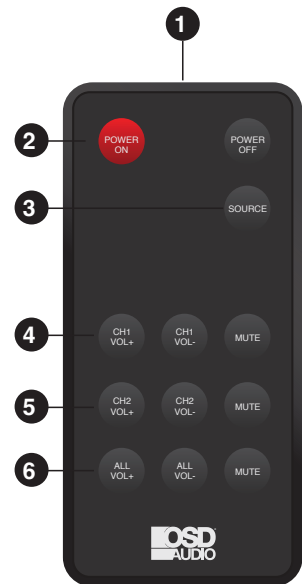

## XPA IR Remote Universal Codes

The XPA 70V Amplifiers IR Remote Controller, controls the individual Power On/Off, Source, and the Volume Levels for Channels 1/3 & 2/4 and All Channels combined. It can also be used to teach IR commands to a programmable, integrated universal IR Remote or other IR routing device. The following are the Remote Controller Head Code and Hex codes for the individual buttons:

XPA1000/XPA600 Remote Controller Head Code: 00FF

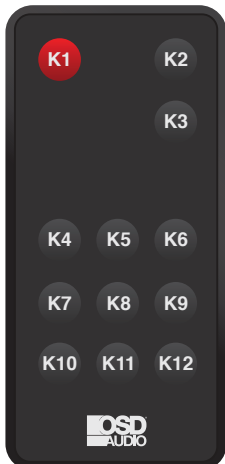

Function Key	Keys	Code	Remark
Power On	K1	45	Power Turn Amplifier On
Power Off	K2	47	Power Turn Amplifier Off
CH1 VOL +	K3	16	CH1/CH3 VOL UP
CH1 VOL -	K4	19	CH1/CH3 VOL DOWN
CH1 SOURCE	K5	0D	CH1/CH3 Source: Unbalanced/Balanced
CH2 VOL +	K6	0C	CH2/CH4 VOL UP
CH2 VOL -	K7	18	CH2/CH4 VOL DOWN
CH2 SOURCE	K8	5E	CH2/CH4 Source: Unbalanced/Balanced
All VOL +	K9	08	CH1+Ch2 and CH3 + CH4 VOL UP
All VOL -	K10	1C	CH1+Ch2 and CH3 + CH4 VOL DOWN
All MUTE	K11	5A	CH1+Ch2 and CH3 + CH4 Silence All Audio on AMP

# IR CODES & RS232 COMMANDS

## XPA1000/XPA600 RS232 Commands

XPA600 XPA1000 RS232 Instruction Correspondence Table			
<b>SOURCE</b>	CH1 toggle input	Send	A55A010F16
	CH2 toggle input	Send	A55A0AFF16
	input poll(Now)	Send	A55A01FF16
	CH1 RCA IN	Return	A55A010016
	CH1 BAL IN	Return	A55A010116
	CH2 RCA IN	Return	A55A020116
	CH2 BAL IN	Return	A55A020216
	CH1 RCA IN	Send	A55A07FF16
		Return	A55A010016
	CH1 BAL IN	Send	A55A08FF16
		Return	A55A010116
	CH2 RCA IN	Send	A55A09FF16
		Return	A55A010216
	CH2 BAL IN	Send	A55A09FD16
	Return	A55A010316	
<b>VOLUME+/-VOLUMEpoll set up ,VOLUME</b>	ALL VOLUME+	Send	A55A05F916
	ALL VOLUME-	Send	A55A05FA16
	CH1 VOLUME+	Send	A55A05FB16
	CH1 VOLUME-	Send	A55A05FC16
	CH2 VOLUME+	Send	A55A05FD16
	CH2 VOLUME-	Send	A55A05FE16
	VOLUME NOW	Send	A55A05FF16
	(0-32)MUSIC VOLUME	Return	A55A08(00-32)16
<b>POWER</b>	POWER ON	Send	A55A060116
	POWER OFF	Send	A55A060016
	POWER NOW	Send	A55A06FF16
	POWER ON	Return	A55A060116
	POWER OFF	Return	A55A060016
<b>MUTE /UNMUTE</b>	all_Unmute	Send	A55A0C0016
	ch1_mute/Unmute	Send	A55A0C0116
	ch2_mute/Unmute	Send	A55A0C0216
	all_mute/Unmute	Send	A55A0C0316
	mute NOW	Send	A55A0CFF16
	ch1_Unmute	Return	A55A0C0416
	ch2_Unmute	Return	A55A0C0516
	ch1_mute	Return	A55A0C0116
	ch2_mute	Return	A55A0C0216
	all_Unmute	Return	A55A0C0016
	all_mute	Return	A55A0C0316

# WARRANTY

OSD Audio electronics have (2) year Limited Warranty against defects in materials and workmanship. Proof of purchase must accompany all claims. During the warranty period OSD Audio will replace any defective part and correct any defect in workmanship without charge for either parts or labor.

OSD Audio may replace returned electronics with a product of equal value and performance. In such cases, some modifications to the mounting may be necessary and are not OSD Audio's responsibility.

For this warranty to apply, the unit must be installed and used according to its written instructions. If necessary, repairs must be performed by OSD Audio. The unit must be returned to OSD Audio at the owner's expense and with prior written permission. Accidental damage and shipping damage are not considered defects, nor is damaged resulting from abuse or from servicing performed by an agency or person not specifically authorized in writing by OSD Audio.

OSD Audio sells products only through authorized dealers and distributors to ensure that customers obtain proper support and service. Any OSD Audio product purchased from an unauthorized dealer or other source, including retailers, mail order dealers and online sellers will not be honored or serviced under existing OSD Audio warranty policy. Any sale of product by an unauthorized source or other manner not authorized by OSD Audio shall void the warranty on the applicable product.

Damage to or destruction of components due to application of excessive power voids the warranty on those parts. In these cases, repairs will be made on the basis of the retail value of the parts and labor. To return for repairs, you must email customer service at [RMA@audiogeargroup.com](mailto:RMA@audiogeargroup.com) for a Returned Merchandise Authorization (RMA) number then the unit must be shipped to OSD Audio at the owner's expense, along with a note explaining the nature of service required. Be sure to pack the product(s) in a corrugated container with at least 3 inches of resilient material to protect the unit from damage in transit.

This Warranty Does Not Cover: Damage caused by abuse, accident, misuse, negligence, or improper operation (installation) • Any products that have been altered or modified • Any product whose identifying number of decal, serial #, etc. has been altered, defaced or removed • Normal wear and maintenance.

